

## UNDER COUNTER GLASS DOOR

REFRIGERATOR  
MODEL : KGR18-3



### ≡ FEATURES / BENEFITS ≡

#### ■ HOT GAS CONDENSATE SYSTEM

Through Turbo Air's creative innovation, the condensate system surfaces have been specially treated to resist corrosion. This not only increases efficiency without the risk of refrigerant leakage from corrosion, but also prevents the overflow of condensate water.

#### ■ SIDE MOUNT COMPRESSOR UNIT

By positioning the compressor on the side of the unit, refrigerators can now be serviced without being moved. Our innovative, front breathing feature also allows this model to provide high efficiency in narrow spaces.

#### ■ EFFICIENT REFRIGERATION SYSTEM

Turbo Air's glass door refrigerators are designed with oversized and balanced refrigeration systems. These include efficient evaporators and condensers for faster cooling and greater efficiency.

#### ■ EXTERIOR & INTERIOR OF THE CABINET

The Turbo Air K series boasts a stainless steel exterior (galvanized steel back and bottom). Interior is stainless steel floor with AL sides, back and AL door liners. It guarantees the utmost in cleanliness and long product life. It can add a touch of style to the most refined setting.

#### ■ HIGH-DENSITY POLYURETHANE INSULATION

The entire cabinet structure and solid doors are foamed-in-place using high density, CFC free polyurethane insulation.

#### ■ MAGNETIC DOOR GASKETS

Magnetic door gaskets are of one piece construction, removable without tools for ease of cleaning and replacement.

#### ■ ADJUSTABLE, HEAVY DUTY, PE (POLYETHYLENE) COATED WIRE SHELVES

#### ■ ERGONOMICALLY DESIGNED DOORS

Customers' fatigue fades away with easy grip handles and doors that open effortlessly. These features along with self-closing doors make this the ultimate choice in customer convenience.

Model	Swing Door	Capacity (litres)	#of Shelves	HP	AMPS	Crated Weight (kg)	W x D x H (mm)
KGR18-3	3	516	3	1/3	3.0	127	1800 x 700(600) x 850

# UNDER COUNTER GLASS DOOR

**REFRIGERATOR**  
**MODEL : KGR18-3**

## Model : KGR18-3

## PLAN VIEW

(unit : mm)

SPEC SHEET	KGR18-3
Classification	Refrigerator
Cabinet dimension (WxDxH mm)	1800x700(600)x850
Capacity (Liters)	516
Inner Temperature	1°C ~ 8°C
Ambient Temperature	40°C
Doors	3
# of shelves	3
Refrigerant	R-134a
Compressor (HP)	1/3
Cooling Type	Fan cooling type
Insulation Type	Polyurethane/ Cyclopentane+CFC Free
Temperature Control Type	Digital
Amps (A)	3.0
Voltage (V/Hz/Ph)	240V 50Hz 1Ph
Power (W)	366
Weight (Kg)	127

Design and specifications subject to change without notice.  
Actual shipping weight may differ due to extra packing materials for product protection.

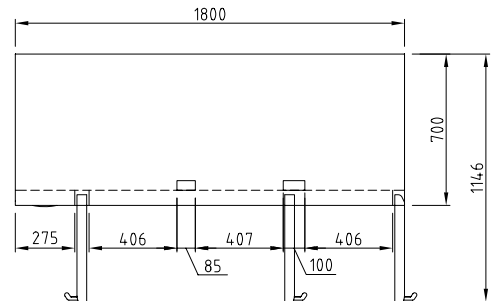

TOP VIEW

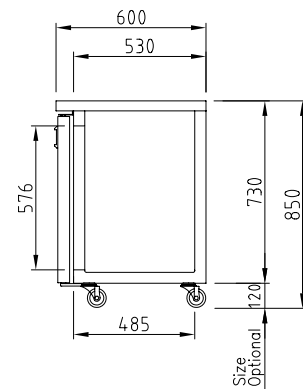

SIDE VIEW  
(Depth 600mm)

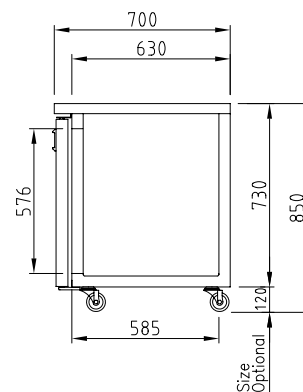

SIDE VIEW  
(Depth 700mm)

- DOOR LOCKS STANDARD
- INTERIOR LED LIGHTING STANDARD
- SELF-CONTAINED SYSTEM
- STANDARD 4 SWIVEL CASTERS WITH LOCKS ON THE FRONT SET
- ALUMINIUM DOOR FRAME
- LOW-E DOUBLE GLASS
- DEPTH 600MM AVAILABLE UPON REQUEST

**WARRANTY 2 YEARS**  
PARTS & LABOUR



AUSTRALIA SOLE IMPORTER

**Turbo air**

**KITCHEN  
KNOCK**

KITCHEN KNOCK Pty Ltd  
[www.kitchenknock.com.au](http://www.kitchenknock.com.au)  
Building E/290 Parramatta Rd,  
Auburn NSW 2144 Australia  
T. 02 9648 0221