

## UNDER COUNTER SOLID DOOR

**DUAL TEMP**  
**MODEL : KURF12-2**



### ≡ FEATURES / BENEFITS ≡

#### ■ HOT GAS CONDENSATE SYSTEM

Through Turbo Air's creative innovation, the condensate system surfaces have been specially treated to resist corrosion. This not only increases efficiency without the risk of refrigerant leakage from corrosion, but also prevents the overflow of condensate water.

#### ■ SIDE MOUNT COMPRESSOR UNIT

By positioning the compressor on the side of the unit, refrigerators can now be serviced without being moved. Our innovative, front breathing feature also allows this model to provide high efficiency in narrow spaces.

#### ■ EFFICIENT REFRIGERATION SYSTEM

Turbo Air's solid door dual temp units are designed with oversized and balanced refrigeration systems. These include efficient evaporators and condensers for faster cooling / freezing and greater efficiency.

#### ■ EXTERIOR & INTERIOR OF THE CABINET

The Turbo Air K series boasts a stainless steel exterior (galvanized steel back and bottom). Interior is stainless steel floor with AL sides, back and AL door liners. It guarantees the utmost in cleanliness and long product life. It can add a touch of style to the most refined setting.

#### ■ HIGH-DENSITY POLYURETHANE INSULATION

The entire cabinet structure and solid doors are foamed-in-place using high density, CFC free polyurethane insulation.

#### ■ MAGNETIC DOOR GASKETS

Magnetic door gaskets are of one piece construction, removable without tools for ease of cleaning and replacement.

#### ■ ADJUSTABLE, HEAVY DUTY, PE (POLYETHYLENE) COATED WIRE SHELVES

#### ■ ERGONOMICALLY DESIGNED DOORS

Customers' fatigue fades away with easy grip handles and doors that open effortlessly. These features along with self-closing doors make this the ultimate choice in customer convenience.

Model	Swing Door	Capacity (litres)	#of Shelves	HP	AMPS	Crated Weight (kg)	W x D x H (mm)
KURF12-2	2	R 121 F 136	R 1 F 1	1/3	3	92	1200 x 700 x 850

# UNDER COUNTER SOLID DOOR

**DUAL TEMP**  
**MODEL : KURF12-2**

## Model : KURF12-2

## PLAN VIEW

(unit : mm)

SPEC SHEET	KURF12-2	
Classification	Refrigerator / Freezer	
Cabinet dimension (WxDxH mm)	1200x700x850	
Capacity (Liters)	121	136
Inner Temperature	1°C ~ 8°C	-21°C ~ -12°C
Ambient Temperature	38°C	
Doors	2	
# of shelves	1	1
Refrigerant	R-134a	
Compressor (HP)	1/3	
Cooling Type	Fan cooling type	
Insulation Type	Polyurethane/ Cyclopentane+CFC Free	
Temperature Control Type	Digital	
Amps (A)	3	
Voltage (V/Hz/Ph)	240V 50Hz 1Ph	
Power (W)	316	
Weight (Kg)	92	

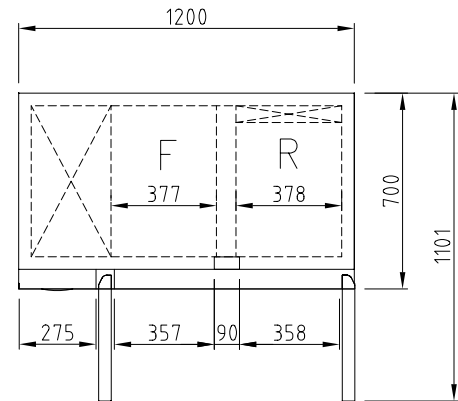

PLAN VIEW

Design and specifications subject to change without notice.  
Actual shipping weight may differ due to extra packing materials for product protection.

- DOOR LOCKS STANDARD
- INTERIOR LED LIGHTING STANDARD
- SELF-CONTAINED SYSTEM
- STANDARD 4" SWIVEL CASTERS WITH LOCKS ON THE FRONT SET

**WARRANTY** **2 YEARS**  
PARTS & LABOUR

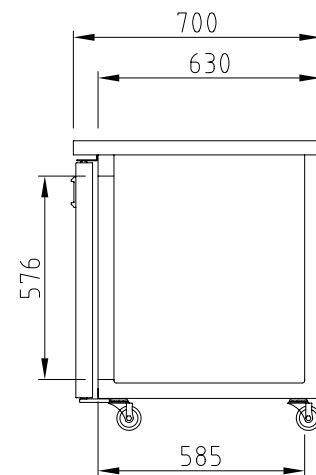

SIDE VIEW

## AUSTRALIA BRANCH

**Turbo air**

TURBO AIR PTY LTD  
[www.turboairinc.com.au](http://www.turboairinc.com.au)  
Ground floor, Building E  
10 Highgate St, Auburn  
NSW 2144 Australia  
T. 02 9737 9881