



# Eswood

# Professional

# Warewasher

**UT20P**

Professional Pot Washer



# Eswood

## Recirculating Pot Washer

The UT20P machine is specially designed to accommodate pots, pans, baking trays, mixing bowls, bun pans, tote boxes, standard Australian baking trays and kitchen utensils.

Top and bottom revolving wash and rinse arms provide a powerful and thorough wash action, and the new water jet designs with knife-like action, blast and strip heavy baked on dirt from all soiled surfaces. No damage to utensils thanks to wash jet balancing, reducing the need for hold-down devices.

The front operation design provides easy access to the inside of the machine and for loading and unloading.

The UT20P conforms to the highest of health and sanitary standards, meeting FSANZ safe food codes and certifications in HACCP and WaterMark.

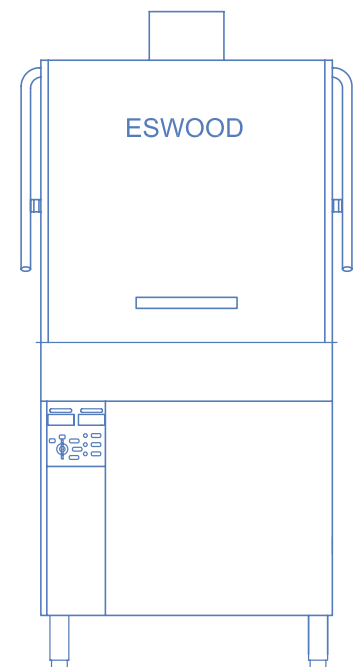



---

Chamber opening up to 540mm clear

---

Durable stainless steel wash and rinse arms

---

Independent wash and rinse systems with high volume pumps for powerful wash action

---

Accurate digital temperature displays

---

2, 4 & 6 minutes wash cycle times

---

---

Machine starts upon a push of a button

---

Wash & rinse pump fitted a standard

---

Operation interlocked to rinse temperature

---

Pass-Through model available

---

- A. Drain connection 2" BSP Gravity
- B. Hot Water Connection 1/2" BSP
- C. Electrical connection 3 phase 415V + N

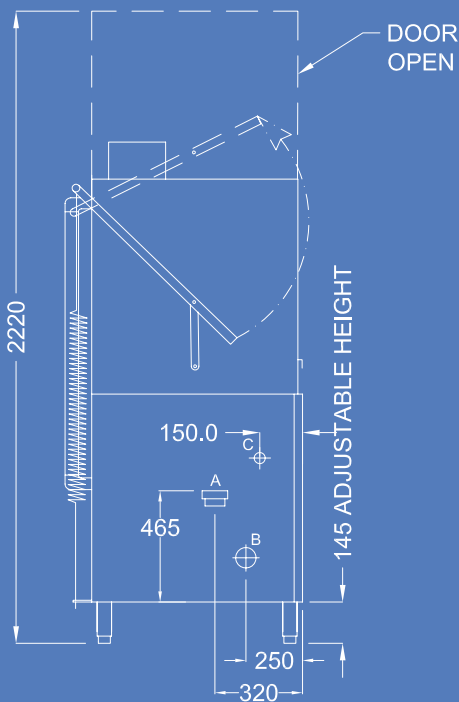
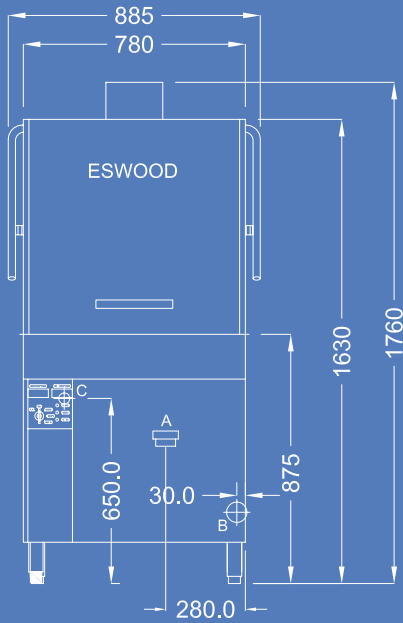
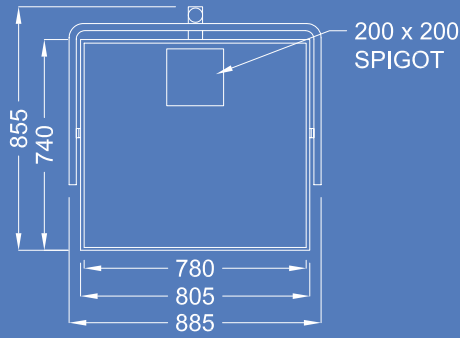

# UT20P

## Professional Pot Washer

### UT20P Specifications

<b>DIMENSIONS (WxDxH)</b>	805 x 855 x 1760 mm
<b>HEIGHT WITH DOOR OPEN</b>	2220 mm
<b>WASH CHAMBER (WxDxH)</b>	665 x 630 x 840 mm
<b>RACK SIZE &amp; OPENING (WxDxH)</b>	660 x 610 x 540 mm
<b>WEIGHT</b>	160 kg
<b>ELECTRIC CONNECTION</b>	3 Phase - 415V + N
<b>RATING</b>	13.5 kW
<b>WATER SUPPLY</b>	60°C / 2-4 bar (28-56 psi)
<b>PACKED</b>	1.5m <sup>3</sup>
<b>WASH CYCLE</b>	2 mins 4 mins 6 mins
<b>WASH AND RINSE PUMP</b>	Fitted
<b>WATER CONSUMPTION</b>	5L Cycle
<b>TANK CAPACITY</b>	70L
<b>WATERMARK APPROVAL</b>	WM-022833
<b>HACCP APPROVAL</b>	PE-388-GE-09

Dimensions may change without notice in accordance with product development and design

Proudly Distributed By

[middleby.com.au](http://middleby.com.au)

211-217 Woodpark Road SMITHFIELD NSW 2164

T: 1800 013 123

E: [sales@middleby.com.au](mailto:sales@middleby.com.au)