

Casette Flat Glass Door LED Display Fridge

| Vertical Display & Storage



Casette Flat Glass Door LED Display Fridge

| Vertical Display & Storage

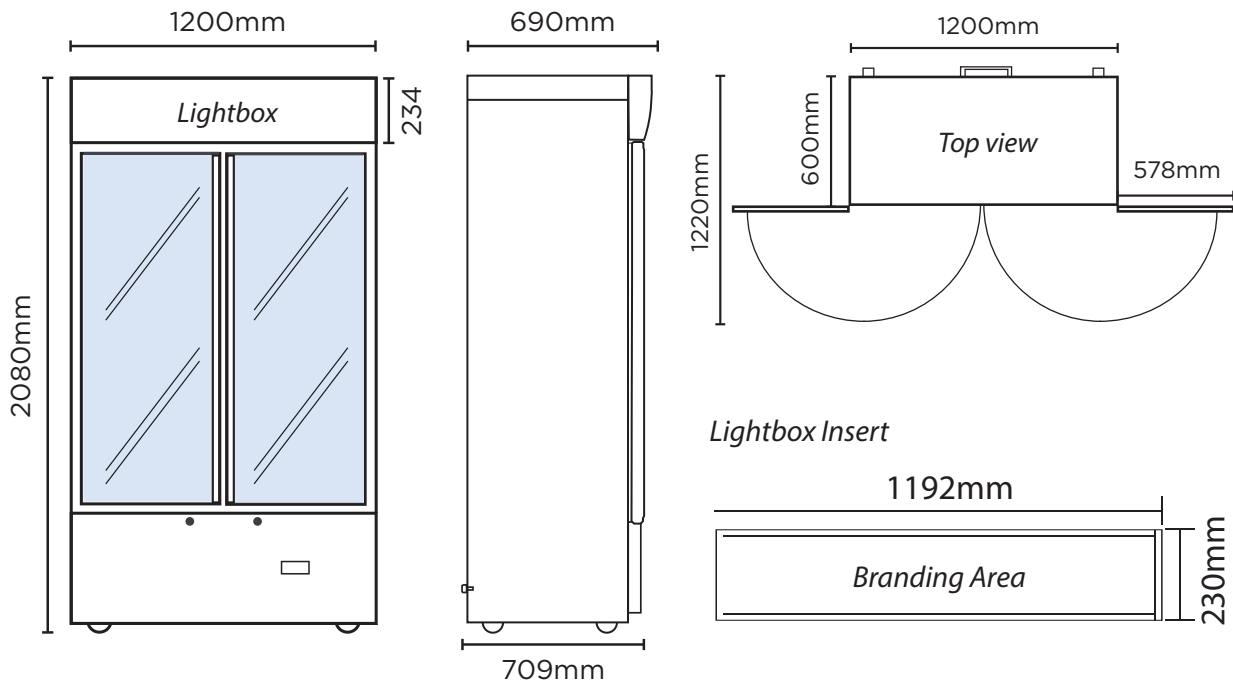

SPECIFICATIONS				DIMENSIONS	
Model Number	GM1000LBCAS	Colour	Black	External (mm)	
Part Number	3736251	Display Light Box	Yes	Width	1200
Volume	960L	Internal Light	LED	Depth	690
Unit Weight	188kg	No. of Doors	2	Height	2080
Packaged Weight	193kg	Door Type	Glass	Internal (mm)	
Adjustable Temp. Range	+2°C to +5°C	Door Glass Type	Double glazed	Width	1090
Max. Ambient Temp.	38°C	Door Style	Hinged	Depth	545
Climate Class	3M1	Door Shape	Flat	Height	1465
Energy Consumption	6.86kWh/24h	Door Swing Dimension	660mm	Packaged (mm)	
GEMS Star Rating	6 stars	Total Depth of door open	1220mm	Width	1270
Refrigeration Capacity	520W	Self-Closing Door	Yes	Depth	755
Refrigerant	R290	Door Lock	Yes	Height	2112
Rated Current	2.3A	No. of Shelves incl Base	6		
Electrical Voltage	220-240V	Shelf Type	Adjustable		
Frequency	50Hz	Shelves Dimensions	527(w) x 478(d) mm		
Power Supply	Single Phase	Temp. Controller	Digital		
Power Plug	1 x 10A	Castors	Yes		
Plug Location	Bottom Left	Warranty	2 Years Bromic Extra Care Warranty - Labour and Parts		