

Flat Glass Door 1507L LED Display Freezer

| Vertical Display & Storage

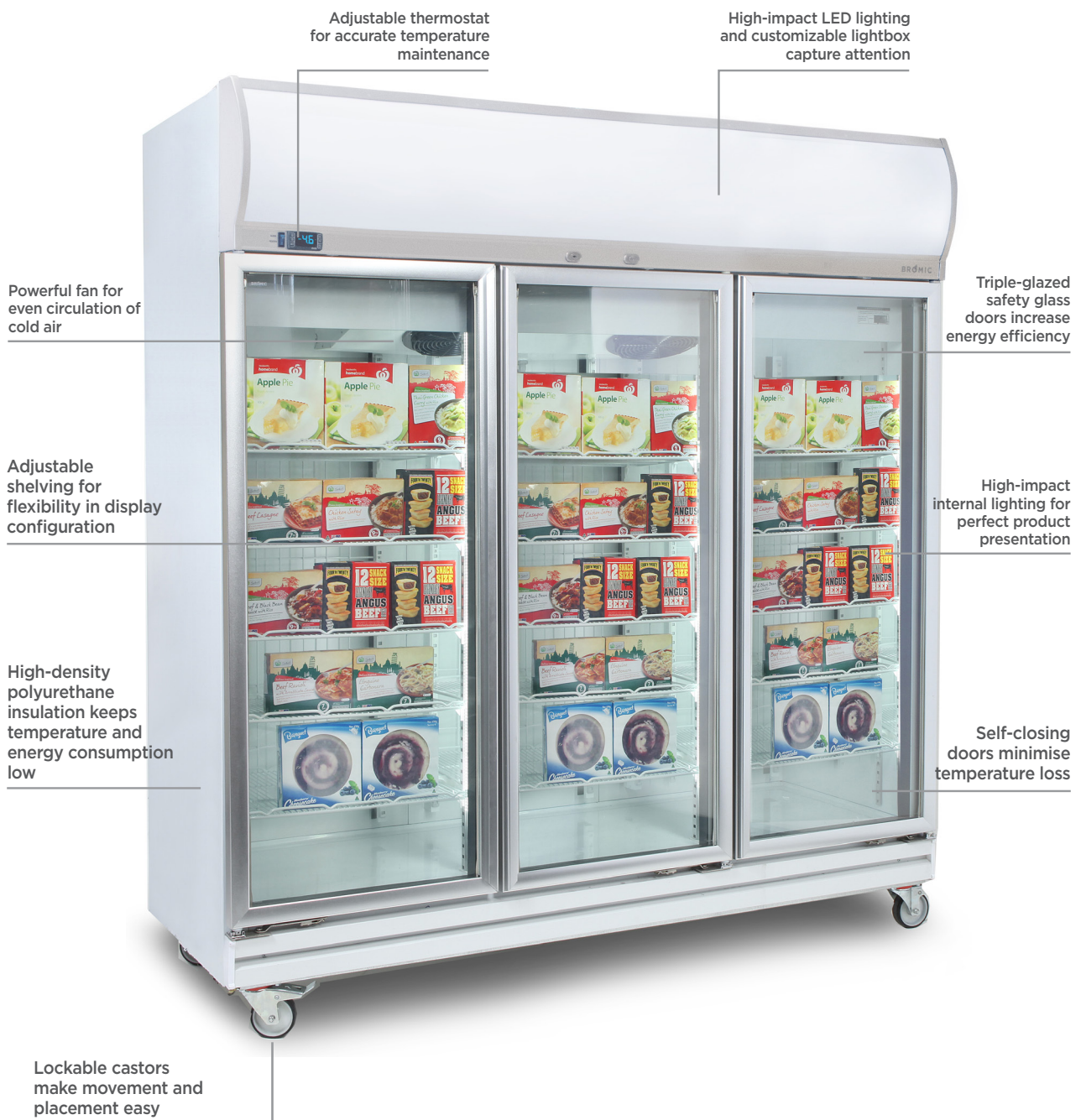

Flat Glass Door 1507L LED Display Freezer

| Vertical Display & Storage

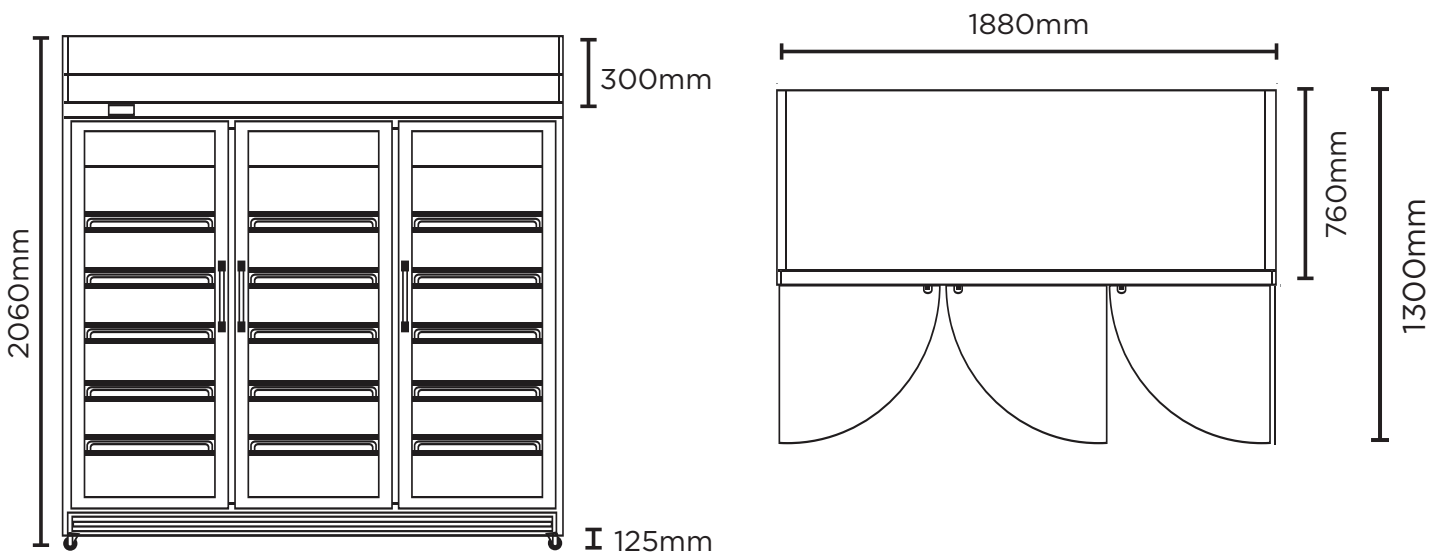

SPECIFICATIONS				DIMENSIONS	
Model Number	UF1500LF	Colour	White with s/steel trim		
Part Number	3736242	Display Light Box	Yes		External (mm)
Volume	1507L	Internal Light	LED	Width	1880
Unit Weight	279	No. of Doors	3	Depth	760
Packaged Weight	284	Door Type	Glass	Height	2060
Adjustable Temp. Range	-22 to -18°C	Door Glass Type	Triple glazed		
Max. Ambient Temp.	38°C	Door Style	Hinged		Internal (mm)
Climate Class	3L1	Door Shape	Flat		
Energy Consumption	32.9kWh/24h	Door Swing Dimension	720mm	Width	1755
GEMS Star Rating	1 star	Total Depth of door open	1300mm	Depth	550
Refrigeration Capacity	2000W	Self-Closing Door	Yes	Height	1420
Refrigerant	R404a	Door Lock	Yes		
Rated Current	9A	No. of Shelves incl Base	6		Packaged (mm)
Electrical Voltage	220-240V	Shelf Type	Adjustable	Width	1950
Frequency	50Hz	Shelves Dimensions	10 x 546(w) x 475(d) mm, 5 x 600(w) x 475(d) mm	Depth	820
Power Supply	Single Phase	Temp. Controller	Digital	Height	2130
Power Plug	1 x 15A	Castors	Yes		
Plug Location	Top right	Warranty	2 Years Bromic Extra Care Warranty - Labour and Parts		