

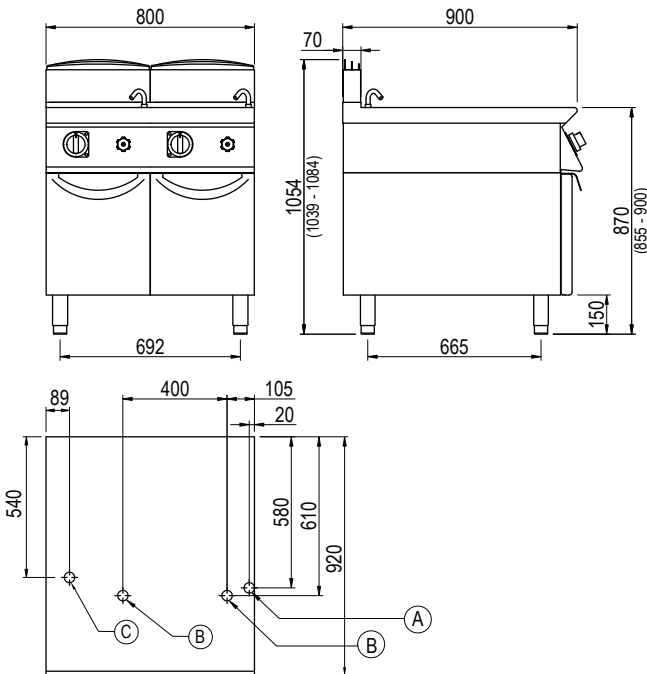

Product Information:

- Class leading, European style, professional quality and reliability since 1963
- 900 series, electric 2 x 40 litre, double tank pasta cooker (19.4kW)
- Heating elements positioned external to the tank for ease of cleaning inside
- Complete with Hi-limit temperature protection and manual reset
- Temperature regulation via 3 position selectors
- Low-water level safety switch to prevent operation when empty
- Manual water fill via integrated tap and spout with water drainage via concealed ball valve inside the base
- Indicator lights to monitor the correct operation of the appliance
- 316 grade stainless steel tanks (2x 340x510mm) for corrosion resistance
- Robust 304 grade stainless steel construction with rounded corners for improved cleaning
- Pressed top work surface with raised edges to protect from overflow
- Enclosed base with front access doors
- Height adjustable stainless steel feet for a 900mm working height
- Baskets and lids not included, sold separately (see below)
- 24-month warranty

General Drawing:



Basket configurations:

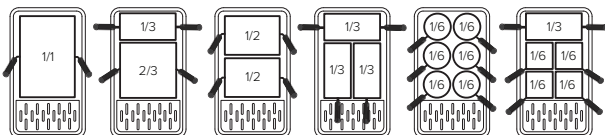

Specifications:

Model	CPE946T
W x D x H (mm)	800 x 920 x 1054
Weight	100kg
Capacity	2 x 40L
Packed Dimensions (mm)	845 x 1025 x 1200
Packed Weight (mm)	112kg
Electrical Connection	3Ø + N + E 415VAC / 50Hz / 19.4kW

Legend:

- A** Electrical Connection
- B** Drain Connection 1" BSP
- C** Cold Water Connection 1/2" BSP

Accessories - Sold Separately

SPGI.2004152	Lid
SPGI.2101603	1/1 GN Basket
SPGI.2003074	1/2 GN Basket
SPGI.2003080	1/6 GN Round Basket
SPGI.2003045	1/6 GN Basket - right handle
SPGI.2003047	1/6 GN Basket - left handle
SPGI.2003046	1/3 GN Basket - left to right
SPGI.2003075	2/3 GN Basket
SPGI.2003077	1/3 GN Basket - front to back

Due to continuous product research and development, the information contained herein is subject to change without notice.

Revision: 01 - 25/01/2022 - A

www.stoddart.com.au

www.stoddart.co.nz

