

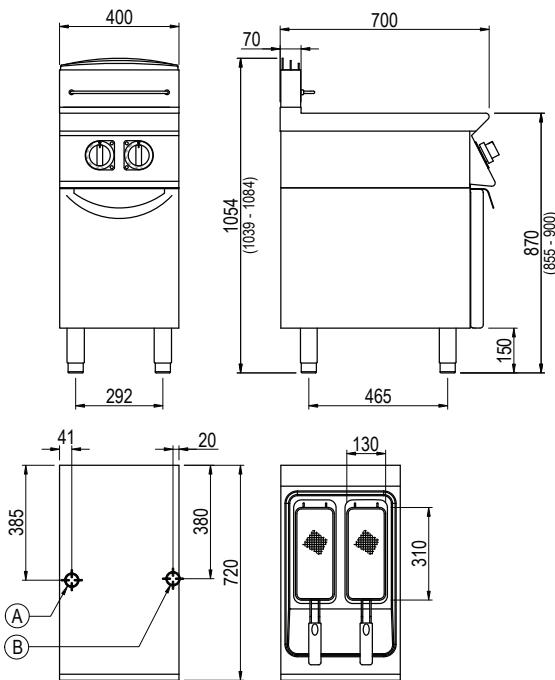

Product Information:

- Class leading, European style, professional quality and reliability since 1963
- 700 series, gas 2 x 8 litre, split pan fryer (43.2 MJ/h)
- Split pan design with immersed tube heat exchangers
- Electronic ignition, high efficiency, nickel plated cast iron burners complete with flame failure device, pilot burner and Hi-limit temperature protection with manual reset
- Temperature regulation via thermostat (100°C – 195°C)
- Thermostat bulbs protected against accidental impact
- Cold zone on the bottom of the tank to collect residues and prevent tainting of oil
- 2x 140x345mm single tanks with oil drainage via ball valve into integrated oil capture drawer
- Indicator lights to monitor the correct operation of the appliance
- Robust 304 grade stainless steel construction with rounded corners for improved cleaning
- Pressed top work surface with raised edges to protect from overflow
- Enclosed base with front access door
- Height adjustable stainless steel feet for a 900mm working height
- Supplied with removable mesh basket support, 2x 130x310x120mm twin baskets and lid
- 24-month warranty

General Drawing:



Specifications:

Model	FG7207TT	
W x D x H (mm)	400 x 720 x 1054	
Weight	73kg	
Oil Capacity	2 x 8L	
Packed Dimensions (mm)	450 x 825 x 1200	
Packed Weight (mm)	78kg	
Electrical Connection	1Ø + N + E 240VAC / 50Hz / 0.2kW 10A plug & lead fitted	
Gas Connection	Natural 1/2" BSP	Universal LPG 1/2" BSP
Minimum Normal Test Gas Pressure	1.3 kPa	2.75 kPa
Maximum Normal Test Gas Pressure	3.5 kPa	3.5 kPa
Nominal Test Point Pressure	1.0 kPa	2.65 kPa
Total Nominal Gas Consumption	43.2 MJ/h	43.2 MJ/h

Note: It is the responsibility of the installing gas plumber to ensure correct supply and connection sustaining appropriate pressure, when all installed gas appliances are operating at maximum.

Legend:

- A** Gas Connection
- B** Electrical Connection