

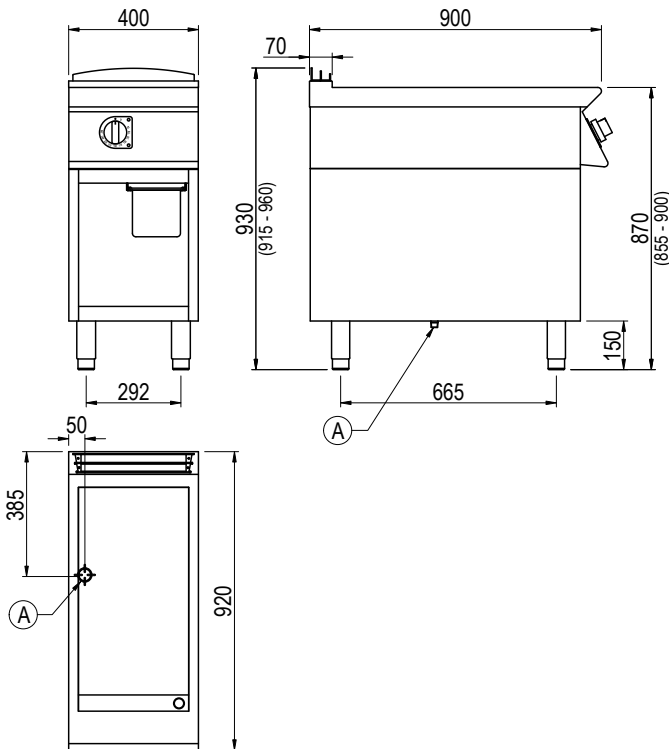

Product Information:

- Class leading, European style, professional quality and reliability since 1963
- 900 series, electric frytop with 12mm smooth mild steel plate (8.6kW)
(also available in 12mm ribbed mild steel plate)
- Heating elements with HI-limit temperature protection
- Temperature regulation via thermostat (80°C – 290°C)
- Indicator light to monitor the correct operation of the appliance
- Robust 304 grade stainless steel construction with rounded corners for improved cleaning
- Hermetically sealed, pressed work surface with raised edges to protect from overflow
- Removable 1/3 GN grease tray
- Open base with optional door available (SPGI.2016437)
- Height adjustable stainless steel feet for a 900mm working height
- 24-month warranty

General Drawing:



Specifications:

Model - Smooth	FLE92GFT
Model - Ribbed	FRE92GFT
W x D x H (mm)	400 x 920 x 930
Weight	92kg
Cooktop (mm)	340 x 460
Packed Dimensions (mm)	450 x 1025 x 1200
Packed Weight (mm)	99kg
Electrical Connection	3Ø + N + E 415VAC / 50Hz / 8.6kW

Legend:

A Electrical Connection

Due to continuous product research and development, the information contained herein is subject to change without notice.

Revision: A - 08/08/2022 - 02

www.stoddart.com.au

www.stoddart.co.nz

