

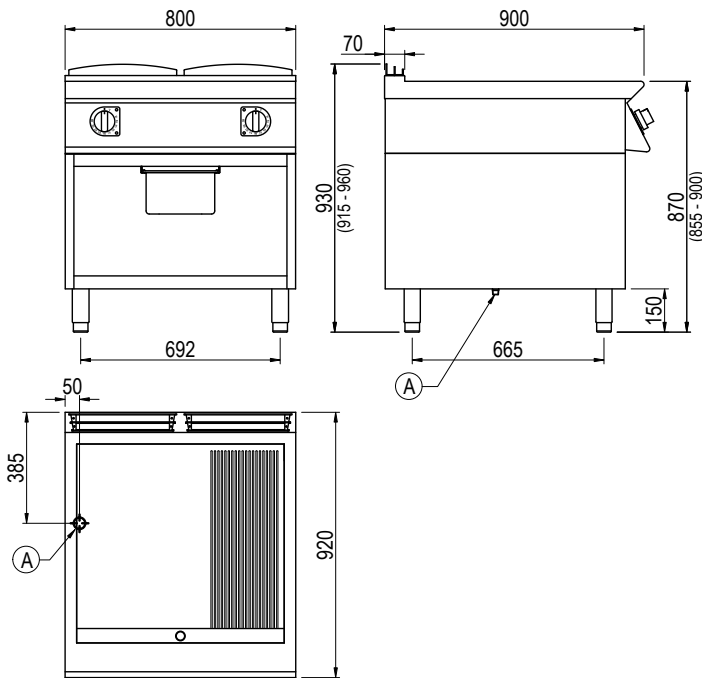

**Product Information:**

- Class leading, European style, professional quality and reliability since 1963
- 900 series, electric frytop with 2/3 smooth and 1/3 ribbed 15mm satin chrome plate (17.2kW)
- Satin chrome plate delivers a cost effective, highly durable, faster heating and easier cleaning solution than alternative plates
- Heating elements with Hi-limit temperature protection
- Temperature regulation via thermostat (80°C – 290°C)
- Indicator lights to monitor the correct operation of the appliance
- Robust 304 grade stainless steel construction with rounded corners for improved cleaning
- Hermetically sealed, pressed work surface with raised edges to protect from overflow
- Removable 1/2 GN grease tray
- Open base with optional doors available (SPGI.2016437)
- Height adjustable stainless steel feet for a 900mm working height
- 24-month warranty

**General Drawing:**



**Specifications:**

<b>Model</b>	FME941GCRXT
<b>W x D x H (mm)</b>	800 x 920 x 930
<b>Weight</b>	175kg
<b>Cooktop (mm)</b>	720 x 640
<b>Packed Dimensions (mm)</b>	845 x 1025 x 1200
<b>Packed Weight (mm)</b>	187kg
<b>Electrical Connection</b>	3Ø + N + E 415VAC / 50Hz / 17.2kW

**Legend:**

A Electrical Connection

Due to continuous product research and development, the information contained herein is subject to change without notice.

Revision: A - 08/08/2022 - 02

[www.stoddart.com.au](http://www.stoddart.com.au)

[www.stoddart.co.nz](http://www.stoddart.co.nz)

