

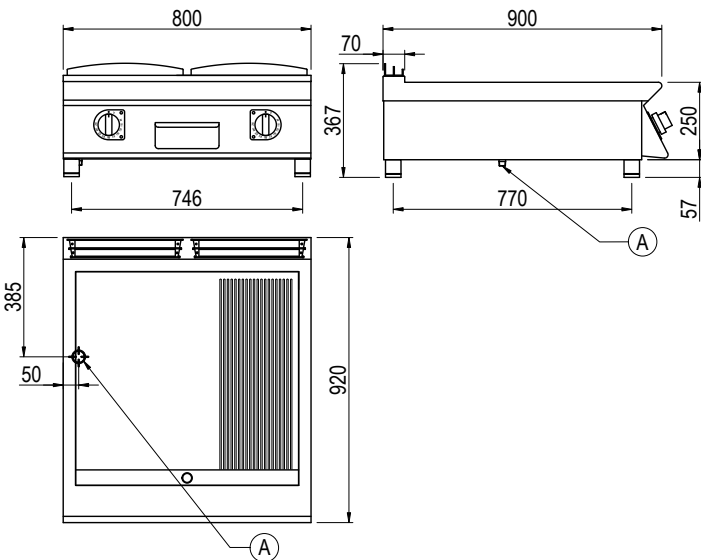

Product Information:

- Class leading, European style, professional quality and reliability since 1963
- 900 series, electric frytop with 2/3 smooth and 1/3 ribbed 15mm satin chrome plate (17.2kW)
- Satin chrome plate delivers a cost effective, highly durable, faster heating and easier cleaning solution than alternative plates
- Heating elements with Hi-limit temperature protection
- Temperature regulation via thermostat (80°C – 290°C)
- Indicator lights to monitor the correct operation of the appliance
- Robust 304 grade stainless steel construction with rounded corners for improved cleaning
- Hermetically sealed, pressed work surface with raised edges to protect from overflow
- Removable grease tray
- 24-month warranty

General Drawing:



Specifications:

Model	FME941TCRXT
W x D x H (mm)	800 x 920 x 367
Weight	140kg
Cooktop (mm)	720 x 640
Packed Dimensions (mm)	845 x 1025 x 570
Packed Weight (mm)	152kg
Electrical Connection	3Ø + N + E 415VAC / 50Hz / 17.2kW

Legend:

A Electrical Connection

Due to continuous product research and development, the information contained herein is subject to change without notice.

Revision: A - 08/08/2022 - 02

www.stoddart.com.au

www.stoddart.co.nz

