



Goldstein

800 SERIES GAS CHARGRILLS

BQG36-X



Standard features and benefits

- Heavy duty welded stainless steel body for rigidity and durability
- Fully welded surrounds
- 2x 20 MJ inline radiant burners per every 305mm section
- Ceramic rocks to increase heat retention and flavour
- 2 char pattern options on reversible cooking grates
- 2 levelling options - flat or gradient
- Constant pilot flame, maximises operating and energy efficiency
- Pilot flame failure on burners
- Front grease trough, generous chute and catcher
- Stainless steel fascia and sides and spill zone for ease of cleaning
- Large, heat resistant reinforced control knob with easy to view settings and high to low flame control
- Adjustable legs
- Easy to service

Other options

- Bench mounted
- Stand with undershelf
- Cupboard stand



Cert. No.
AGA 7732



MIDDLEBY GOLDSTEIN

1800 013 123 | +61 2 9604 7333
sales@middleby.com.au
middleby.com.au

VIC - TAS - 47 Stubbs Street, Kensington VIC 3031
QLD - U12, 210 Queensport Rd Nth, Murarrie QLD 4172
WA - U2, 9 Meares Way, Canning Vale WA 6155

**HEAD OFFICE
AND MANUFACTURING PLANT**
211-217 Woodpark Road, Smithfield NSW 2164

v1_2024



BQG36-X

800 SERIES GAS CHARGRILLS

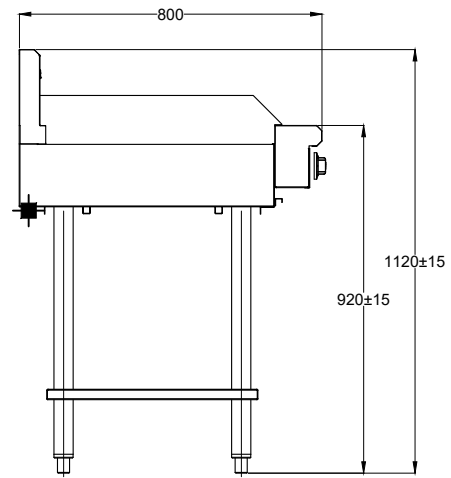
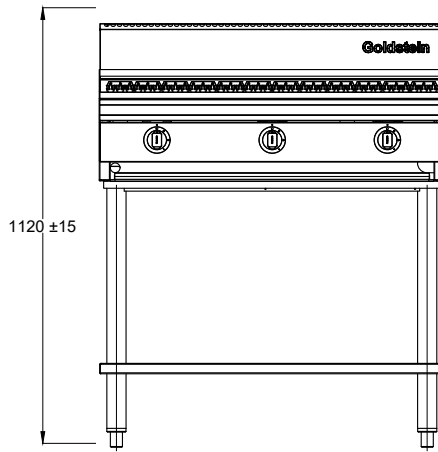
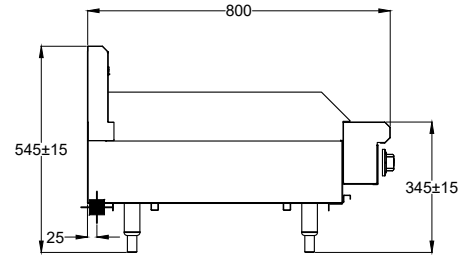
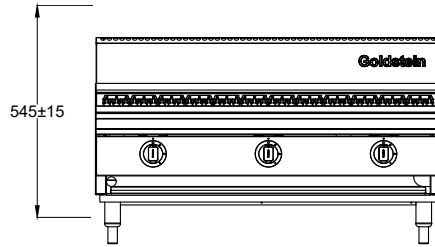
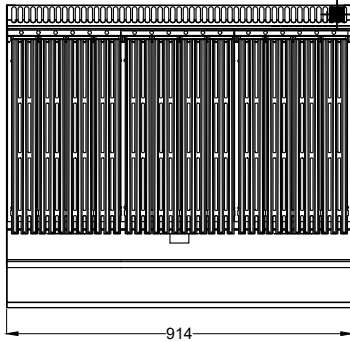

■ 3/4" BSP Gas Connection

SPECIFICATIONS

Dimensions (WxDxH)	bench mounted	914 x 800 x 545 mm
	on stand	914 x 800 x 1120 mm
Grill size		914 x 510 mm

Gas connection	3/4" BSPM
Rating NG/LPG	120/114 MJ
Packed dimensions without stand	980 x 900 x 870 mm

Available in Natural and LP gas

INSTALLATION CLEARANCES (minimum)

Combustible Material	Sides	250* mm
	Back	50 mm

Non-combustible Material	Sides	0 mm
	Back	0 mm

Note: * If adjacent surface is of combustible material and is 100mm below the cooking surface, then only 50mm clearance is required.

Please note, due to ongoing product development and improvement, we reserve the right to change product design and specification at any time without notice.



1800 013 123 | +61 2 9604 7333
sales@middleby.com.au
middleby.com.au

VIC - TAS - 47 Stubbs Street, Kensington VIC 3031
QLD - U12, 210 Queensport Rd Nth, Murarrie QLD 4172
WA - U2, 9 Meares Way, Canning Vale WA 6155

HEAD OFFICE AND MANUFACTURING PLANT
211-217 Woodpark Road, Smithfield NSW 2164

v1_2024